

# Vibra Shake™ Dust Collector

**Models VS-550, -1200, -1500, -2400, -3000**

**A self-cleaning collector that is best for intermittent applications where high collection efficiency is essential, such as reclaiming precious metals.**

- Two-stage cartridge for high-efficiency filtration on both coarse and fine dusts.
- Compact, self-contained collector design allows placement flexibility and saves floor space.
- Preassembled for easy, low-cost installation—no need for compressed air.
- Selection of inlet size and location for installation flexibility.
- Recirculates filtered air saving heating and cooling costs.
- Productivity increases and morale improves by providing a cleaner working environment.
- Reduces plant maintenance costs.



**VS-550**

**Vibra Shake cartridge features patented Pleatloc™ corrugation that assures uniform pleat spacing for better self-cleaning and longer filter life.**

- Filter screen captures coarse and fibrous particles.
- Submicron particulates pass through the filter screen and are trapped by the inner layer of media.
- Galvanized outer liner protects filter media.
- Easy filter changeout for quicker maintenance.



# Vibra Shake Collector

## Operational Explanation

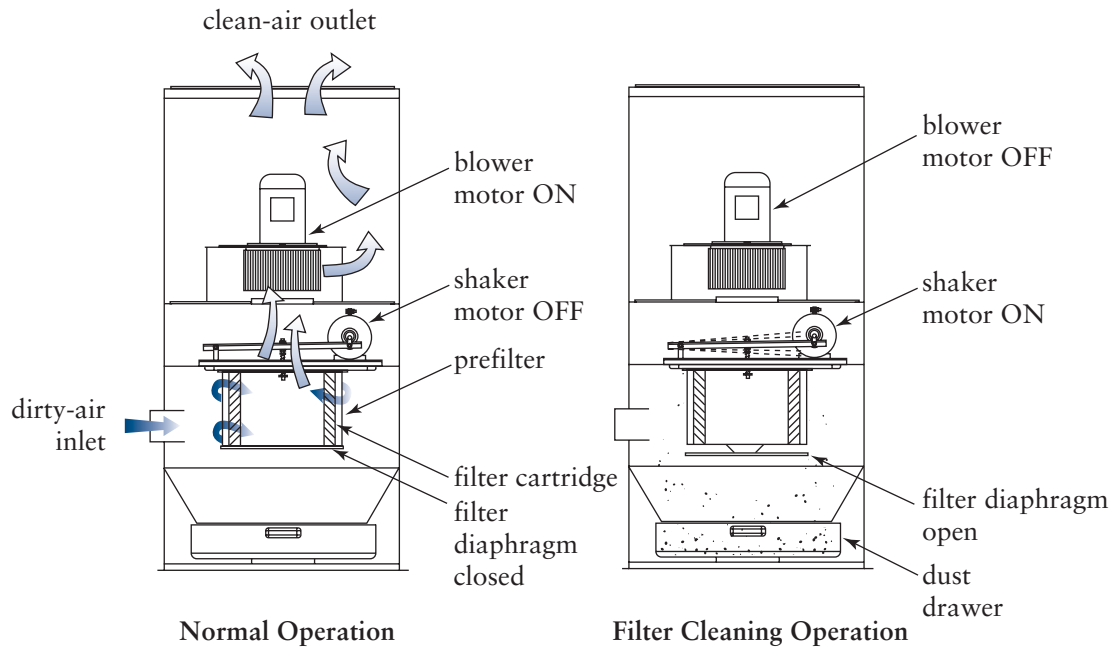

Automatic mechanical self-cleaning ensures the filter cartridge is cleaned every time the unit is shut off. It does an excellent job more cost effectively, and it does it quietly because of heavy-duty construction, special sound-attenuating material, and a vibration isolation motor mount.

## Multiple Rating Table

Model	Nominal Airflow* (cfm)	Motor (hp)	Inlet (inches)	External Static Pressure ("wg)
<b>VS-500</b>	550	1	4	4.3
	500	1	4	4.3
	450	1	4	4.6
	400	1	4	4.7
<b>VS-1200</b>	1243	3	6	4.8
	1100	3	6	5.8
	1000	3	6	6.2
	800	3	6	7.2
	700	3	6	7.5
<b>VS-1500</b>	1525	5	7	3.0
	1447	5	7	3.6
	1348	5	7	4.2
	1200	5	7	5.2
	1000	5	7	6.0

Model	Nominal Airflow* (cfm)	Motor (hp)	Inlet (inches)	External Static Pressure "wg
<b>VS-2400</b>	2400	5	8	5.7
	2200	5	8	6.2
	2000	5	8	6.7
	1800	5	8	7.0
	1600	5	8	7.2
	1400	5	8	7.4
<b>VS-3000</b>	3300	7.5	10	4.4
	3000	7.5	10	5.2
	2800	7.5	10	5.8
	2600	7.5	10	6.6
	2400	7.5	10	7.1
	2200	7.5	10	7.6
	2000	7.5	10	8.0
	1800	7.5	10	8.2

\* Based on clean filters.

# Vibra Shake Collector

## Dimensions & Specifications

Model	Nominal Airflow* (cfm)	Filter Area (ft <sup>2</sup> )	Dust Drawer Volume (cu ft)	Shipping Weight Dust Drawer (lbs)	Shipping Weight Hopper (lbs)	Sound Level dB(A)**
VS-550	550	65	1.8	350	490	69
VS-1200	1200	135	1.8	370	510	74
VS-1500	1500	177	1.8	385	525	79
VS-2400	2400	270	3.6	685	960	81
VS-3000	3000	354	776	1050	83	

\* Based on clean filters.

\*\* Published dB(A) sound levels are for units without HEPA filter and are an overall average. This average is determined for one operating condition and in a controlled laboratory environment. Actual installed equipment sound levels will vary depending on the measurement location, the operating condition, the installation, and the environment.

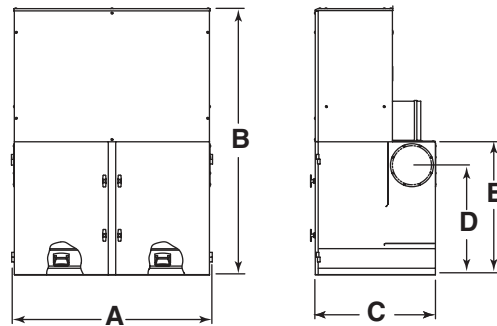
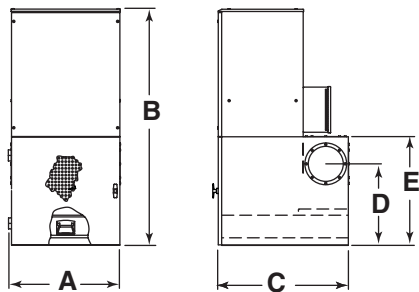
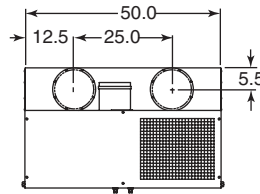
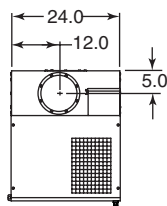

VS-550, 1200 and 1500 Dust Drawer

VS-2400 and 3000 Dust Drawer

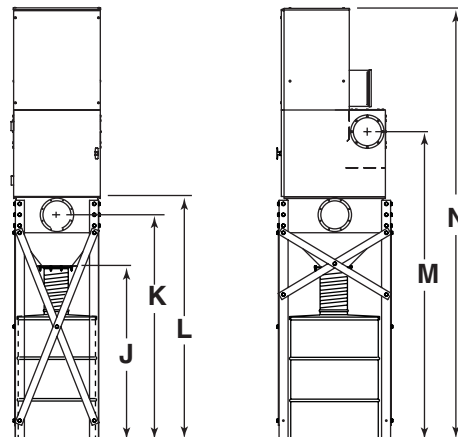
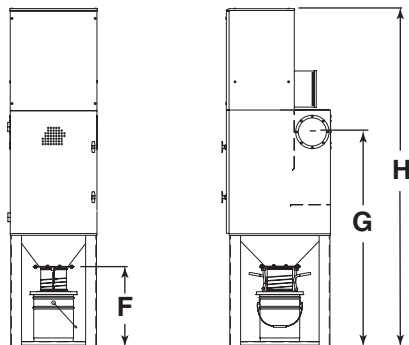

5-Gallon Pail  
VS-550, 1200, and 1500 Only

Hopper and 55-Gallon Drum  
All Models

Model	Dimensions (inches)												
	A	B	C	D	E	F	G	H	J	K	L	M	N
VS-550	24.7	52.2	30.8	18.1	24.1	22.3	49.5	83.7	48.0	62.3	67.3	85.3	119.4
VS-1200	24.7	62.2	30.8	28.1	34.1	22.3	59.3	93.7	48.0	62.3	67.3	101.4	129.4
VS-1500	24.7	68.2	30.8	34.1	40.1	22.3	65.5	99.7	48.0	62.3	67.3	107.4	135.4
VS-2400	51.3	69.2	33.0	28.1	34.2	--	--	--	48.0	--	--	103.6	144.7
VS-3000	51.3	75.2	33.0	34.1	40.1	--	--	--	48.0	--	--	109.6	150.7

# Vibra Shake Collector

## Standard Features & Equipment Options

	Standard	Optional		Standard	Optional
<b>Collector Design</b>			<b>Paint System</b>		
Integral Fan Housing with Motor	X		Prime Coated Interior	X	
Shaker Motor 1/8 hp, 115/60/1 TENV	X		Blue Exterior Finish Coating Meets 250-Hour Salt Spray Corrosion Protection Test	X	
Inlet Collar	X		Custom Color		X
Hinged Cartridge Access Door	X		Hostile Environment Coating		X
Prewired Cleaning Control NEMA 12	X		Epoxy Coating		X
Prewired Starter Controls		X	<b>Hopper Discharge</b>		
Louver Pack		X	Dust Drawer Base	X	
Casters		X	5-Gallon Pail Pack with and without Gate		X
Outriggers with 4-in. Casters (VS-550-1500)		X	55-Gallon Drum Arrangement with and without Gate (does not include drum)		X
Silencers (VS-2400 and VS-3000)		X	Slide Gate		X
Extraction Arm		X	<b>Electrical Controls, Gauges and Enclosures</b>		
<b>Cartridge Filters</b>			Magnehelic®* Gauge		X
Two-Stage Filtration	X		<b>Warranty</b>		
HEPA Afterfilters		X	10-Year Warranty	X	

\* Magnehelic is a registered trademark of Dwyer Instruments, Inc.



Donaldson Company, Inc.  
 Industrial Air Filtration  
 P.O. Box 1299  
 Minneapolis, MN 55440  
 Tel 800-365-1331(USA)  
 Tel 800-343-3639 (within Mexico)  
 dustmktg@mail.donaldson.com  
 www.donaldson.com

Significantly improve the performance of your collector with genuine Donaldson Torit replacement filters and parts.

**Visit us at [www.donaldsondynamic.com](http://www.donaldsondynamic.com)**

Information in this document is subject to change without notice.

© 1998 Donaldson Co., Inc.  
 Printed in U.S.A. on recycled paper

Data Sheet Vibra Shake (10/05)



Visit us online at [DustCollectionPros.com](http://DustCollectionPros.com)

# Our Business is Improving Your Workplace Air Quality.



**S**ince 1995, Environmental Solutions has been helping businesses, like yours, improve their workplace air quality. As an authorized service center for Donaldson Torit, we offer you a one-stop shop for equipment, service, engineering and installation of the industry's leading air pollution control systems.

Whether your company requires the removal of oil mist, welding fumes, machining or wood-working dust, graphite, or correction of any other type of air quality problem; we can expertly engineer and install a quality Donaldson Torit solution to meet your unique needs. No system is too big or too small.

**TOLL FREE 1-866-438-7891**

 **Environmental**  
*Solutions*

12427 Fire Island Drive  
Loves Park, IL 61111  
Phone: (847) 370-9304

Environmental Solutions is also your source for discount pricing on genuine Donaldson Torit Replacement Filters!

---

DONALDSON TORIT SALES | INSTALLATION | REPLACEMENT FILTERS